

GNSS CALIBRATION REPORT

G1G2_ 1016-2023

Prepared by: Carmen Vélez (ROA)

Approved by: Héctor Esteban (ROA)

Authorized by: BIPM

Project: EURAMET_ROA_G1G2

Code: 1016-2023

Version: 1.0

Date: 13/07/2023

TABLE OF CONTENTS

1. INTRODUCTION	4
1.1. SCOPE OF THE DOCUMENT	4
1.2. DOCUMENT STRUCTURE	4
1.3. DOCUMENTS	5
1.4. ACRONYMS AND ABBREVIATIONS	5
2. PARTICIPANTS AND SCHEDULE	7
3. THE ROA TRAVELING EQUIPMENT	8
4. CALIBRATION PROCEDURE.....	9
5. DATA PROCESSING.....	10
6. UNCERTAINTY ESTIMATION.....	12
7. FINAL RESULTS	13
8. ANNEX-A.....	14
8.1. CALIBRATION INFORMATION SHEET AT ROA.....	14
8.2. CALIBRATION INFORMATION SHEET AT IFS	16
8.3. CALIBRATION INFORMATION SHEET AT BIM	18
9. ANNEX-B: CCD AT EACH LAB	20

LIST OF TABLES AND FIGURES

Table 1-1: List of Acronyms and Abbreviations.....	5
Table 2-1: List of participants.	7
Table 2-2: Schedule of the campaign and involved receivers.	7
Table 5-1: Initial delays (in ns) of receiver at start of calibration.	10
Table 6-1: Uncertainty contributions for the calibration of receiver delays	12
Table 7-1: GPS calibration results, all values in ns.....	13
Table 7-2: Galileo calibration results, all values in ns.	13
Figure 9-1: Before the calibration trip (GPS).....	20
Figure 9-2: Before the calibration trip (Galileo)	20
Figure 9-3: After the calibration trip (GPS)	21
Figure 9-4: After the calibration trip (Galileo)	21
Figure 9-5: GPS CCD at IFS.....	22
Figure 9-6: Galileo CCD at IFS	22
Figure 9-7: GPS CCD at BIM	23
Figure 9-8: Galileo CCD at BIM	23

1. INTRODUCTION

1.1. SCOPE OF THE DOCUMENT

In 2014, as a result of a CCTF recommendation for a collaboration between the BIPM and the RMOs for GNSS equipment calibration, some National Metrology Institutes (NMIs) and Designated Institutes (DIs), were selected to be G1 laboratories, to function as regional nodes for the GPS calibrations. The mission of these Labs, once calibrated by BIPM, was to perform new calibration trips among G2 laboratories, under the responsibility of RMOs.

ROA, as EURAMET G1 laboratory, organized this year, a GPS receiver relative calibration campaign, which took place at IFS(HR) and BIM(BG).

In this campaign was carried out a differential calibration with closure, where the travelling system served as a transfer between IFS and BIM systems and the reference receiver RO10. This last was calibrated and reported this year (Cal_Id=1016-2023), being continuously monitored since then.

1.2. DOCUMENT STRUCTURE

The current campaign has been carried out in accordance with ROA calibration procedure and following as much as possible the BIPM guidelines for GNSS calibrations [RD02]. The results will be reported using Cal_Id, and they will provide the visited receivers' internal delays for GPS (C1, P1, P2) and Galileo (E1, E5a) code signals.

Section 1 of this document gives the introduction, the document structure and a document baseline (in terms of applicable and reference documents and used acronyms).

Section 2 reports, the participating laboratories, dates of visits, and GPS receivers involved in this calibration campaign.

Section 3 presents an overview of the travelling equipment specifically prepared for this activity.

Section 4 basically describes the calibration procedure.

Section 5 explains the data processing carried out by our own software and all the necessary tables to get the results.

Section 6 is focused in the uncertainty estimation, in all the terms taken into account for the uncertainty budget.

Section 7 shows the final results, with the new internal delays, as well as all the necessary information to get them.

The report concludes with the Annex-A for each visited receiver, and the Annex-B, which contains all the figures with the common clock differences (CCD).

1.3. DOCUMENTS

REFERENCES	
RD01	BIPM report 1001-2020 V1.2 / 20210712, subject: 2021 Group 1 GNSS calibration trip (Phase 2).
RD02	BIPM guidelines for GNSS calibration, V3.2, 15/02/2016.
RD03	G. Petit, Z. Jiang, P. Moussay, J. White, E. Powers, G. Dudle, P. Uhrich, 2001, Progresses in the calibration of geodetic like GPS receivers for accurate time comparisons, Proc. 15th EFTF, pp. 164-166.
RD04	p. Defraigne, C. Bruyninx, 2001, Time Transfer for TAI using a geodetic receiver, An Example with the Ashtech ZXII-T, GPS Solutions, 5(2), pp. 43-50.
RD05	J. Kouba, P. Heroux, 2002, Precise Point Positioning Using IGS Orbit and Clock Products, GPS Solutions, Vol. 5, No. 2, pp. 12-28.

1.4. ACRONYMS AND ABBREVIATIONS

Table 1-1: List of Acronyms and Abbreviations

Acronym	Definition
BIM	Bulgarian Institute of Metrology.
BIPM	Bureau International des Poids et Mesures.
CCD	Common Clock Difference.
CCTF	Consultative Committee for Time and Frequency.
CGGTTS	CCTF Generic GNSS Time Transfer Standard.
CCTF	Consultative Committee for Time and Frequency.
DI	Designated Institute.
EURAMET	European Association of National Metrology Institutes.
Galileo	European GNSS
GNSS	Global Navigation Satellite System
GPS	Global Positioning System.
IFS	Research Institute of Physics.
IGS	International GNSS Service.
ITRF	International Terrestrial Reference Frame.
MJD	Modified Julian Date.
NMI	National Metrology Institute.
NRCan	Natural Resources Canada.
PPP	Precise Point Positioning.
RINEX	Receiver Independent Exchange Format.
RMO	Regional Metrology Organization.
ROA	Real Instituto y Observatorio de la Armada, San Fernando, Spain.
TDEV	Time Deviation. Is a measure of time stability based on the modified Allan Variance.
TIC	Time Interval Counter.
UTC	Coordinated Universal Time.
UTC(k)	Version of UTC realized at each of the contributing NMIs.

Acronym	Definition
CGGTTS specific acronyms	
CABDLY	Field present in the CGGTTS header. It is the group delay inside the antenna cable, including both end connectors.
INTDLY	Field present in the CGGTTS header. It is the code- and frequency-dependent combined electric delay of the GNSS signal inside the antenna and the receiver. See also [RD03].
REFDLY	Field present in the CGGTTS header. It is the time offset between the receiver internal clock (or its conventional realization by an external signal) and the local clock at the station. See also [RD03].
REFGPS	Time difference between the reference clock and GPS time, for each satellite at the mid-point of the 13 min track. Receiver delay, cable delay, tropospheric delay and (for one single code) modelled ionospheric delay corrections have been applied.

2. PARTICIPANTS AND SCHEDULE

Participating laboratories, dates and GPS receivers involved in the calibration campaign are summarized in Table 2-1 and Table 2-2. Nevertheless, a complete information related with the receiver set-up and the signal distribution system have been provided by all Labs (see relevant Annex-A).

Table 2-1: List of participants.

Institute	Point of contact	Postal address
ROA	Héctor Esteban Tel +34 956599286 hesteban@roa.es	Real Instituto y Observatorio de la Armada Plaza de las Tres Marinas s/n 11100, San Fernando, Spain
IFS	Elinor Trogrlić Tel: +385 98 9844 069 etrogrlic@ifs.hr	Research Institute of Physics (IFS) Bijenička Cesta 46 HR-10000, Zagreb, Croatia
BIM	Natasha Tosheva Tel: +359 2 9702795 n.tosheva@bim.government.bg	Department "Length and time" Bulgarian Institute of Metrology 52-B, Dr.G.M. Dimitrov Blvd 1797, Sofia, Bulgaria

Table 2-2: Schedule of the campaign and involved receivers.

Institute	Status of equipment	Dates of measurements	Receiver type	BIPM code	RINEX code
ROA	Traveling		Septentrio PolarRx5TR		TR
ROA	Group 1 reference	MJD: 60058-60062 24/04/23-28/04/23	Septentrio PolarRx5TR	RO10	RO10
IFS	Group 2 reference	MJD: 60077-60080 13/05/23-16/05/23	Septentrio PolarRx5TR	HR01	HR01
BIM	Group 2 reference	MJD: 60095-60099 31/05/23-04/06/23	GTR51	BM51	BM51
ROA	Group 1 reference	MJD: 60116-60120 21/06/23-25/06/23	Septentrio PolarRx5TR	RO10	RO10

3. THE ROA TRAVELING EQUIPMENT

Traveling equipment consists of one shipping box containing the following items:

- Antenna: NOVATEL GNSS-850, SN: NMLK21450007U
- PolaRx5TR receiver, SN: 4701310
- PolaRx5TR power cable with adaptator
- PolaRx5TR usb cable
- PolaRx5TR Ethernet cable
- Time interval counter Keysigth 53230A, SN: MY60230145
- Keysigth power cable
- Antenna cable (50 m, H155)
- Laptop TOSHIBA, SN: X7052920H (without battery)
- TOSHIBA laptop power cable with adaptator.
- 1 10 dB attenuator
- 1 BNC-BNC female adapter
- 5/8 inch screw
- 2 BNC cables.

As it is shown in the equipment list, only one receiver was used as traveling equipment. We used a direct antenna cable to connect the PolaRx5TR and the Novatel antenna.

4. CALIBRATION PROCEDURE

The calibration has been performed based on C1, P3 GPS and E1, E3 CCGTTS Galileo files. Instead using the files automatically generated by each particular receiver, we have generated them from RINEX V.3 observation files, by means of R2CGGTTS software tool V8.3 developed at the Royal Observatory of Belgium [RD04]. This was done to avoid any systematic error induced by the use of a different tropospheric model, and mainly by imprecise antenna positions.

On this latter point, the coordinates of the antenna phase centre at each location have been especially computed for the calibration period from RINEX files by using the NRCAN PPP software [RD05], so the time transfer error caused by this factor is nearly negligible.

Basically, the calibration consists on the following. From the known delays of the reference receiver (RO10) and an average of the traveling receiver delays between the start and the end of the campaign, we can obtain INTDLY(C1), INTDLY(P1) and INTDLY(P2) for the receivers in the visited Labs. As the calibration is consisting in building differential pseudo-ranges for each code C1, P1 and P2 between pairs of receivers in common-clock set-up, they can be easily obtained by using the data collected in C1 and also in P3 CCGTTS files:

$$\gamma = (f_1/f_2)^2 = (77/60)^2$$

$$REFGPS(P1) = REFSYS(P3) + MSIO$$

$$REFGPS(P2) = REFGPS(P3) + \gamma \times MSIO$$

where *MSIO* are the measured ionospheric delays.

In a similar way, with $\gamma = (E1/E5a)^2 = (1575.42/1176.45)^2$, INTDLY(E1) and INTDLY(E5a) can be obtained.

5. DATA PROCESSING

For the calculation process we have used a ROA-authored program, in which the common clock differences (CCD) are obtained from the common-view of CGGTTS files. For each location, the coordinates of the antenna have been carefully calculated for the calibration period.

As was stated before, from the known delays of the reference receiver RO10, it has been obtained the internal delays for each receiver at the visited site. Normally, the antenna cable delay (CABDLY) is maintained without any change, and the reference delay (REFDLY) is normally updated, anyway, any variation with respect to the true values, will be assumed by the INTDLY results.

Table 5-1 summarizes the initial delays of the DK01 receiver at the start of calibration. With these values new CGGTTS files have been generated. Tables 5-2 and 5-3 show the raw CCD differences at the visited Lab.

Table 5-1: Initial delays (in ns) of receiver at start of calibration.

BIPM code	INT DLY C1	INT DLY P1	INT DLY P2	INT DLY E1	INT DLY E5a	REF DLY	CAB DLY
HR01						25.7	240.2
BM51						8.2	218.8

Table 5-2: GPS raw common clock differences, all values in ns.

Pair	RAW $\Delta C1$	Sigma	RAW $\Delta P1$	Sigma	RAW $\Delta P2$	Sigma
TR-HR01	-35.1	0.61	-32.8	0.66	-28.6	0.78
TR-BM51	-30.4	0.79	-30.5	0.77	-30.6	0.59

Table 5-3: Galileo raw common clock differences, all values in ns.

Pair	RAW $\Delta E1$	Sigma	RAW $\Delta E5a$	Sigma
TR-HR01	-35.2	0.50	-33.5	0.64
TR-BM51	-32.2	0.45	-28.0	0.40

Taking a close loop to the closure measurements of Tables 5-4 and 5-5, we can observe a normal behavior of TR receiver, where the C1, P1, P2, E1 and E5a variations have remained relatively constant (below 0.1 ns).

Table 5-4: GPS closure measurements at ROA, all values in ns.

Pair	RAW $\Delta C1$	Sigma	RAW $\Delta P1$	Sigma	RAW $\Delta P2$	Sigma
TR-RO10 (before the trip)	0.00	0.54	-0.03	0.51	-0.05	0.45
TR-RO10 (after the trip)	-0.00	0.30	0.00	0.33	0.00	0.48
Misclosure	0.00		-0.03		-0.05	
Mean	0.00		-0.02		-0.03	

Table 5-5: Galileo closure measurements at ROA, all values in ns.

Pair	RAW $\Delta E1$	Sigma	RAW $\Delta 5a$	Sigma
TR-RO10 (before the trip)	0.00	0.44	0.02	0.46
TR-RO10 (after the trip)	0.01	0.33	-0.04	0.49
Misclosure	-0.01		0.06	
Mean	0.01		-0.01	

6. UNCERTAINTY ESTIMATION

The overall uncertainty of the INT DLY values obtained as a result of the calibration is given by:

$$u_{\text{CAL}} = \sqrt{u_a^2 + u_b^2}, \quad (1) \quad \text{with}$$

with the statistical uncertainty u_a and the systematic uncertainty u_b . The statistical uncertainty is related to the instability of the common clock data collected at each site and collected at ROA when the INT DLY of travelling equipment was determined. The systematic uncertainty is given by:

$$u_b = \sqrt{\sum_n u_{b,n}^2} \quad (2)$$

The contributions to the sum (2) are listed and explained subsequently. In the Table 6-1, we have considered the larger type A uncertainty found at remotes sites, which is quite small, so there is no need to develop it in detail for each Lab. Note that the uncertainty of the INT DLY values of ROA's fixed receiver RO10, which served as the reference, is not included.

Table 6-1: Uncertainty contributions for the calibration of receiver delays

	Uncertainty	Value C1 ns	Value P1 ns	Value P2 ns	Value E1 ns	Value E5a ns	Description
1	$u_{a(\text{ROA})}$	0.10	0.10	0.10	0.10	0.10	CCD uncertainty at ROA, TDEV at $\tau = 1$ day
1	$u_{a(\text{DFM})}$	0.10	0.10	0.10	0.10	0.10	CCD uncertainty at remote Lab, TDEV at $\tau = 1$ day
Systematic components due to misclosure							
2	$u_{b,11}$	0.00	0.03	0.05	0.01	0.06	TR misclosure, see Tables 5-4 and 5-5
Systematic components due to antenna installation							
2	$u_{b,12}$	0.05	0.05	0.05	0.05	0.05	Position error of RO10 receiver
3	$u_{b,13}$	0.05	0.05	0.05	0.05	0.05	Position error at remote Lab.
4	$u_{b,14}$	0.10	0.10	0.10	0.10	0.10	Multipath at ROA.
5	$u_{b,15}$	0.10	0.10	0.10	0.10	0.10	Multipath at remote Lab.
Installation of RO10 and HR01, BM51 receivers							
6	$u_{b,21}$	0.30	0.30	0.30	0.30	0.30	Connection of TR to UTC(ROA) (REFDLY).
7	$u_{b,22}$	0.30	0.30	0.30	0.30	0.30	Connection of TR to UTC(k) (REFDLY).
7	$u_{b,23}$	0.30	0.30	0.30	0.30	0.30	Connection of reference receiver to UTC(ROA) (REFDLY).
7	$u_{b,24}$	0.30	0.30	0.30	0.30	0.30	Connection of receivers at site k to UTC(k) (REFDLY).
7	$u_{b,25}$	0.10	0.10	0.10	0.10	0.10	TIC nonlinearities at ROA.
10	$u_{b,26}$	0.10	0.10	0.10	0.10	0.10	TIC nonlinearities at remote sites.

7. FINAL RESULTS

The results of the internal calibration are summarized in Table 7.1-2. INTDLY and associated uncertainty C1 values have been calculated from Table 5.1-3 and Table 6.1, respectively, rounded to the tenth of a nanosecond (the same for GPS P1, P2 and Galileo E1, E5a codes):

$$\text{INTDLY C1} = -\Delta\text{C1}(\text{Table 5-2/Table 5-3}) + \Delta\text{C1}_{\text{mean}}(\text{Table 5-4/Table 5-5})$$

Table 7-1: GPS calibration results, all values in ns.

Receiver	REF DLY	CAB DLY	INTDLY C1	u _{cal} C1	INT DLY P1	u _{cal} P1	INT DLY P2	u _{cal} P2
HR01	25.7	240.2	35.1	0.7	32.8	0.7	28.6	0.7
BM51	8.2	218.8	30.4	0.7	30.5	0.7	30.6	0.7

Table 7-2: Galileo calibration results, all values in ns.

Receiver	REF DLY	CAB DLY	INTDLY E1	u _{cal} E1	INT DLY E5a	u _{cal} E5a
HR01	25.7	240.2	35.2	0.7	33.5	0.7
BM51	8.2	218.8	32.2	0.7	28.0	0.7

8. ANNEX-A

8.1. CALIBRATION INFORMATION SHEET AT ROA

Laboratory:	ROA	
Date and hour of the beginning of measurements:	24.04.2023	
Date and hour of the end of measurements:	28.04.2023	
Information on the system		
	Local:	Travelling:
4-character BIPM code	RO10	TR
• Receiver maker and type:	Septentrio PolaRx5TR v5.2.0	Septentrio PolaRx5TR v5.3.2
Receiver serial number:	4701187	4701310
1 PPS trigger level /V:	1 V	1 V
• Antenna cable maker and type:	LDF1RK-50	H155
Phase stabilised cable (Y/N):		
Length outside the building /m:	Approximately 37 m	Approximately 50 m
• Antenna maker and type:	LEICA AR25	Novatel antenna GPS-850
Antenna serial number:	726362	NMLK21450007U
Measured delays /ns		
	Local:	Travelling:
• Delay from local UTC to receiver 1 PPS-in:	5.1 ns Auto-compensation PPS IN: ON	287.5 ns Auto-compensation PPS IN: ON
Delay from 1 PPS-in to internal Reference (if different): <small>(see section 2 for details)</small>		
• Delay from local UTC to receiver 1 PPS-out:		
• Antenna cable delay:	199.0 ns	260.6 ns
Antenna cable type:		
Data used for the generation of CGGTTS files		
	Local:	Travelling:
• INT DLY (GPS) /ns:	29.9 ns C1, 28.2 ns P1, 25.7 ns P2	26.9 ns C1, 24.7 ns P1, 23.3 ns P2
• INT DLY (GALILEO) /ns:	30.1 ns E1, 29.7 ns E5a	26.9 ns E1, 28.8 ns E5a
• CAB DLY /ns:	199.0 ns	260.6 ns
• REF DLY /ns:	5.1 ns	287.5 ns
• Coordinates reference frame:	ITRF	ITRF
Latitude or X /m:	5105577.43 m	5105578.85 m
Longitude or Y /m:	-555208.88 m	-555192.38 m
Height or Z /m:	3769714.22 m	3769708.61 m
General information		
• Rise time of the local UTC pulse:		0.5 ns
• Is the laboratory air conditioned:		Yes
Set temperature value and uncertainty:		(22 ± 2) °C
Set humidity value and uncertainty:		< 70 %

Diagram of the experiment set-up:

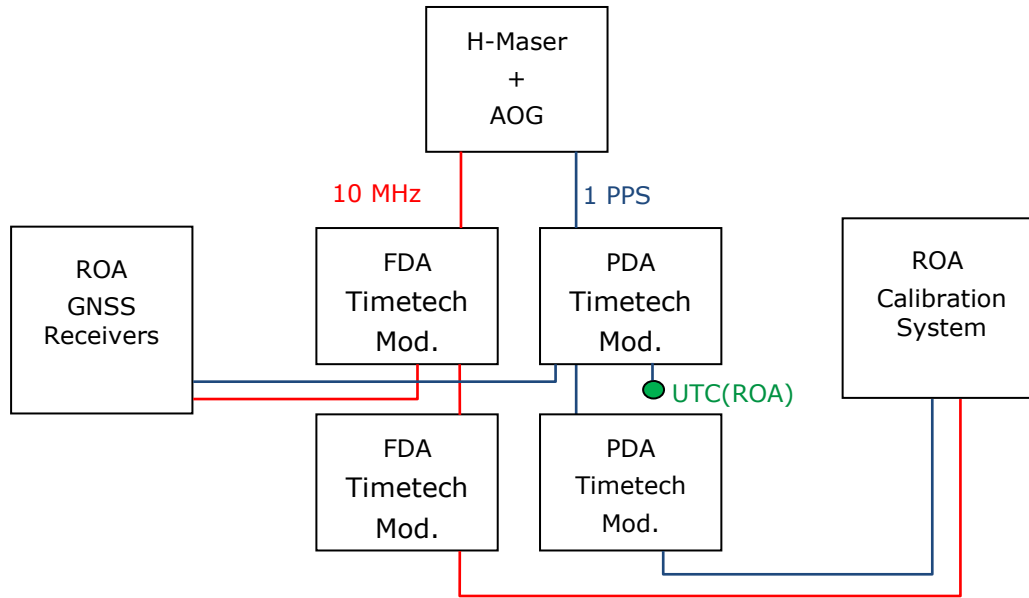

8.2. CALIBRATION INFORMATION SHEET AT IFS

Laboratory:	IFS	
Date and hour of the beginning of measurements:	13.05.2023	
Date and hour of the end of measurements:	16.05.2023	
Information on the system		
	Local:	Travelling:
4-character BIPM code	HR01	TR
• Receiver maker and type:	Septentrio PolaRx5TR v5.5.0	Septentrio PolaRx5TR v5.3.2
Receiver serial number:	3084861	4701310
1 PPS trigger level /V:	1 V	1 V
• Antenna cable maker and type:	CommScope, FSJ4-50B	H155
Phase stabilised cable (Y/N):		
Length outside the building /m:	Approximately 55.3 m	Approximately 50 m
• Antenna maker and type:	SinoGNSS AT600	Novatel antenna GPS-850
Antenna serial number:	J042200013S	NMLK21450007U
Measured delays /ns		
	Local:	Travelling:
• Delay from local UTC to receiver 1 PPS-in:	25.7 ns Auto-compensation PPS IN: ON	37.5 ns Auto-compensation PPS IN: ON
Delay from 1 PPS-in to internal Reference (if different): (see section 2 for details)		
• Total delay:		
• Antenna cable delay:	240.2 ns	260.6 ns
Antenna cable type:		
Data used for the generation of CGGTTS files		
	Local:	Travelling:
• INT DLY (GPS) /ns:	-35.1 ns C1, -32.8 ns P1,- 28.6 ns P2	26.9 ns C1, 24.7 ns P1, 23.3 ns P2
• INT DLY (GALILEO) /ns:	-35.2 ns E1, -33.5 ns E5a	26.9 ns E1, 28.8 ns E5a
• CAB DLY /ns:	240.2 ns	260.6 ns
• REF DLY /ns:	25.7 ns	37.5 ns
• Coordinates reference frame:	ITRF	ITRF
Latitude or X /m:	4280063.35 m	4280049.04m
Longitude or Y /m:	1226104.94 m	1226129.24 m
Height or Z /m:	4552123.08 m	4552128.18m
General information		
• Rise time of the local UTC pulse:	0.5 ns	
• Is the laboratory air conditioned:	Yes	
Set temperature value and uncertainty:	(22 ± 2) °C	
Set humidity value and uncertainty:	< 70 %	

Diagram of the experiment set-up:

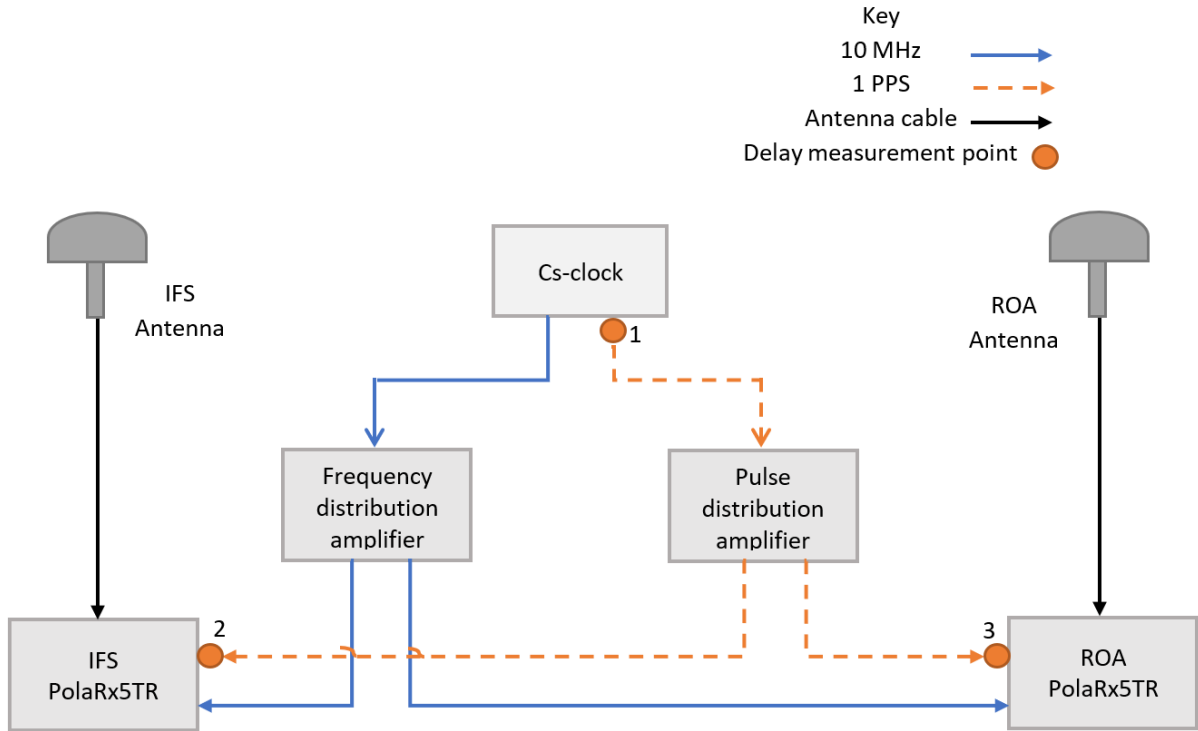

8.3. CALIBRATION INFORMATION SHEET AT BIM

Laboratory:	BIM	
Date and hour of the beginning of measurements:	31.05.2023	
Date and hour of the end of measurements:	04.06.2023	
Information on the system		
	Local:	Travelling:
4-character BIPM code	BM51	TR
• Receiver maker and type:	GTR51	Septentrio PolaRx5TR v5.3.2
Receiver serial number:	1901007	4701310
1 PPS trigger level /V:	1 V	1 V
• Antenna cable maker and type:	TNC-N	H155
Phase stabilised cable (Y/N):		
Length outside the building /m:	Approximately 40	Approximately 50 m
• Antenna maker and type:	Novatel GNSS-850	Novatel antenna GPS-850
Antenna serial number:	NMLK18480066P	NMLK21450007U
Measured delays /ns		
	Local:	Travelling:
• Delay from local UTC to receiver 1 PPS-in:	8.2 ns Auto-compensation PPS IN: ON	7.9 ns Auto-compensation PPS IN: ON
Delay from 1 PPS-in to internal Reference (if different): <small>(see section 2 for details)</small>		
• Total delay:		
• Antenna cable delay:	218.8 ns	260.6 ns
Antenna cable type:		
Data used for the generation of CGGTTS files		
	Local:	Travelling:
• INT DLY (GPS) /ns:	-30.4 ns C1, -30.5 ns P1, -30.6 ns P2	26.9 ns C1, 24.7 ns P1, 23.3 ns P2
• INT DLY (GALILEO) /ns:	-32.2 ns E1, -28.0 ns E5a	26.9 ns E1, 28.8 ns E5a
• CAB DLY /ns:	218.8 ns	260.6 ns
• REF DLY /ns:	8.2 ns	7.9 ns
• Coordinates reference frame:	ITRF	ITRF
Latitude or X /m:	4312764.03 m	4312767.26 m
Longitude or Y /m:	1862536.09 m	1862533.20 m
Height or Z /m:	4300604.85 m	4300603.64 m
General information		
• Rise time of the local UTC pulse:	0.5 ns	
• Is the laboratory air conditioned:	Yes	
Set temperature value and uncertainty:	(22 ± 2) °C	
Set humidity value and uncertainty:	< 70 %	



Diagram of the experiment set-up:

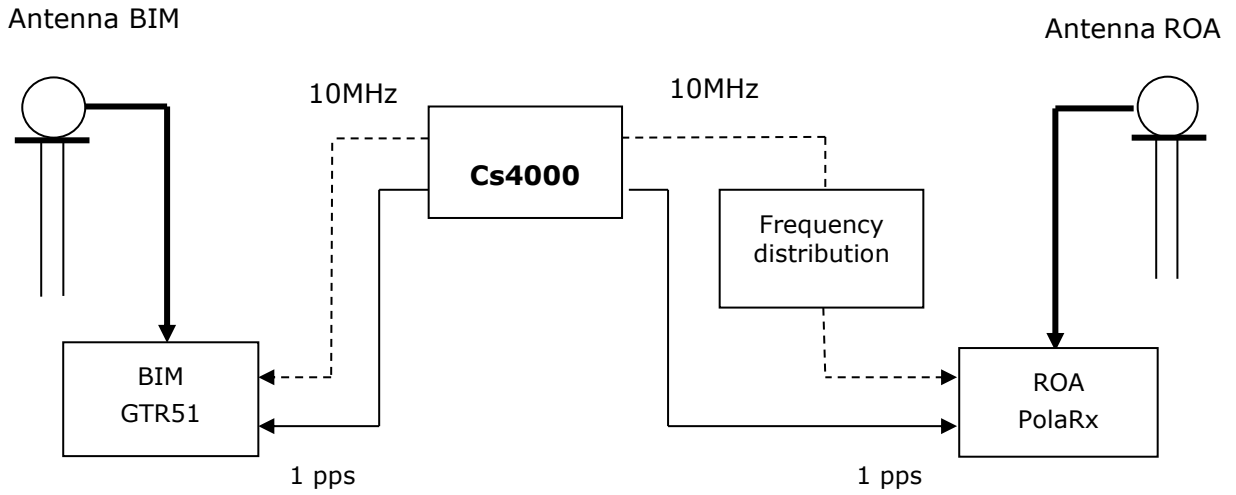



9. ANNEX-B: CCD at each Lab

Figure 9-1: Before the calibration trip (GPS)

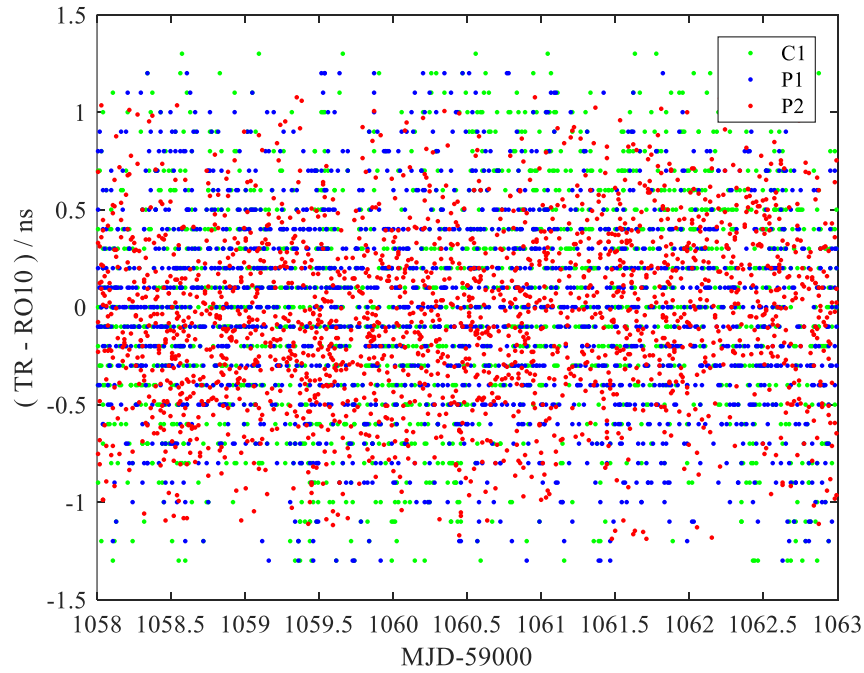

Figure 9-2: Before the calibration trip (Galileo)

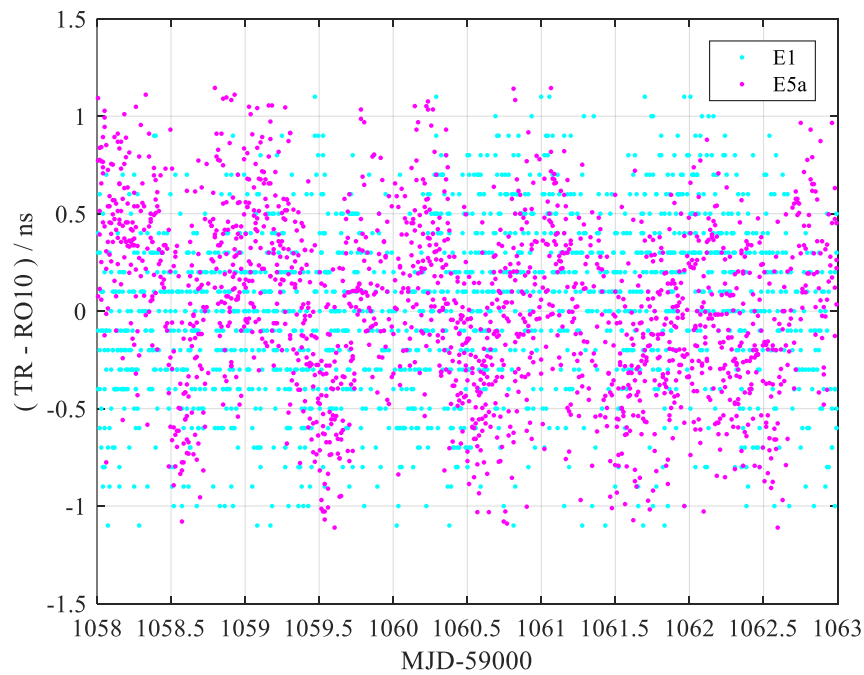



Figure 9-3: After the calibration trip (GPS)

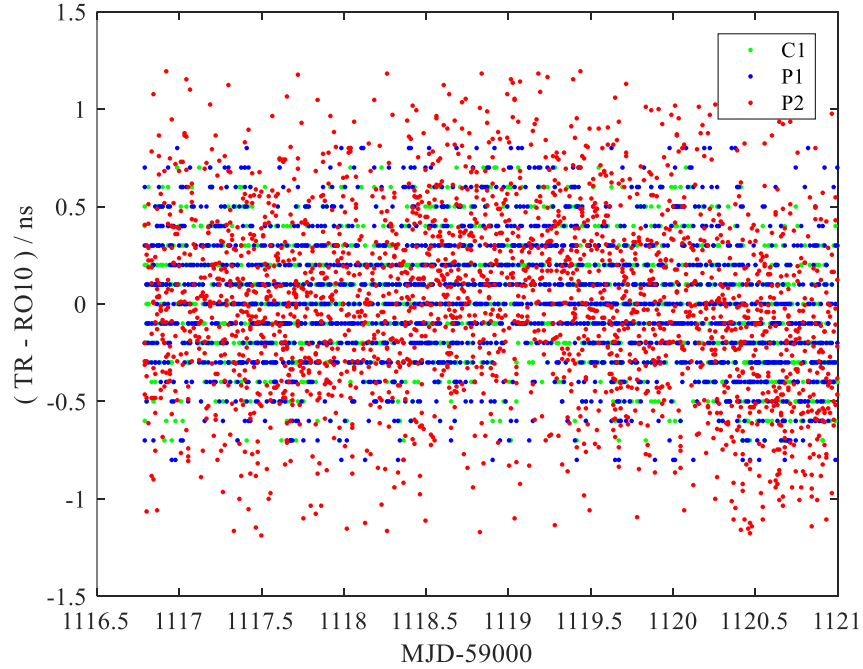

Figure 9-4: After the calibration trip (Galileo)

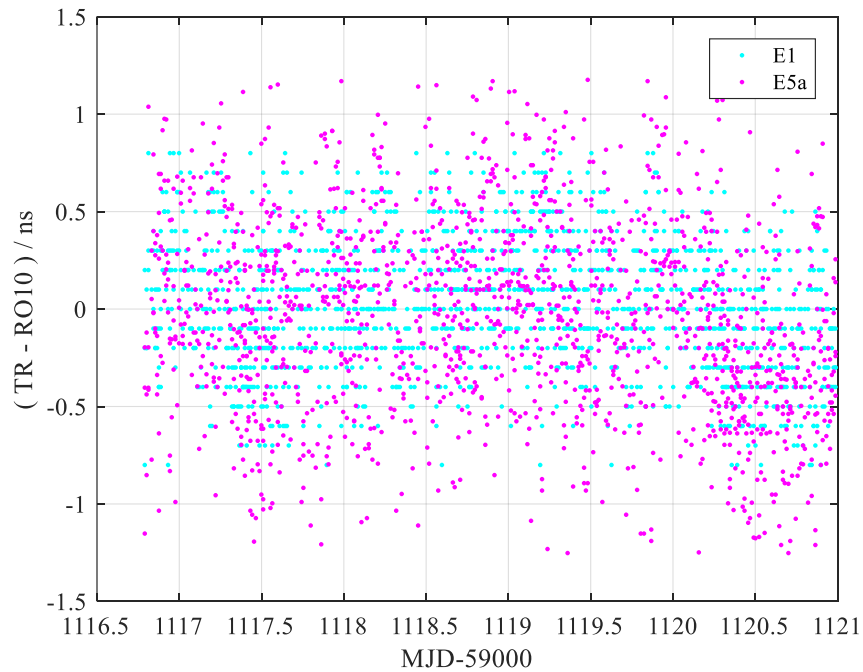



Figure 9-5: GPS CCD at IFS

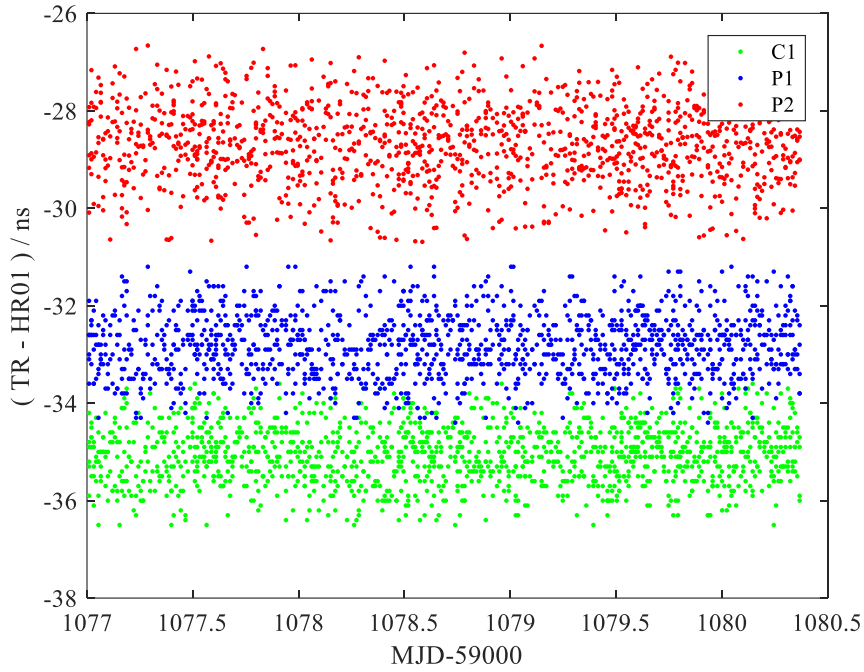

Figure 9-6: Galileo CCD at IFS

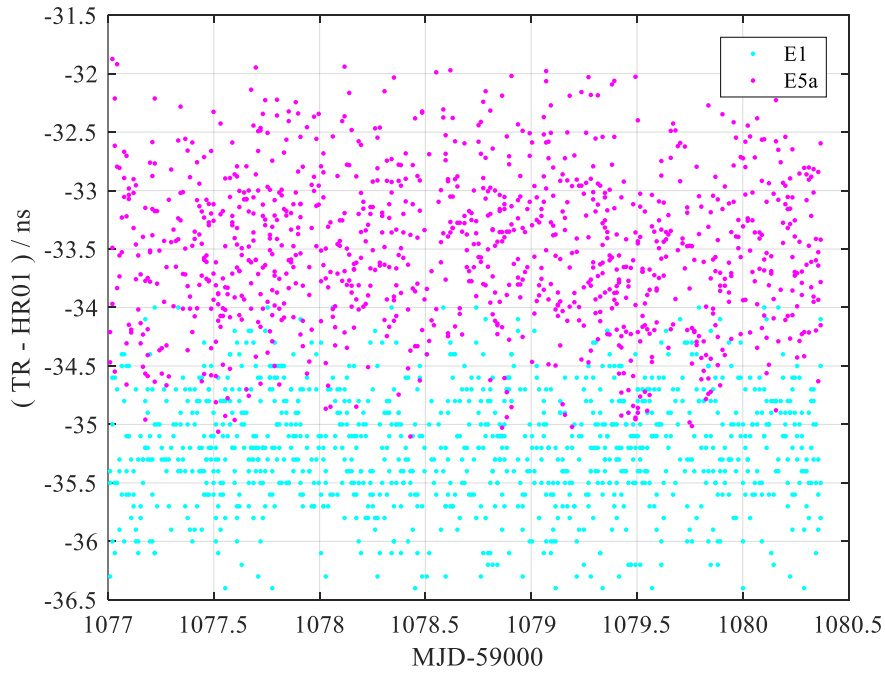

Figure 9-7: GPS CCD at BIM

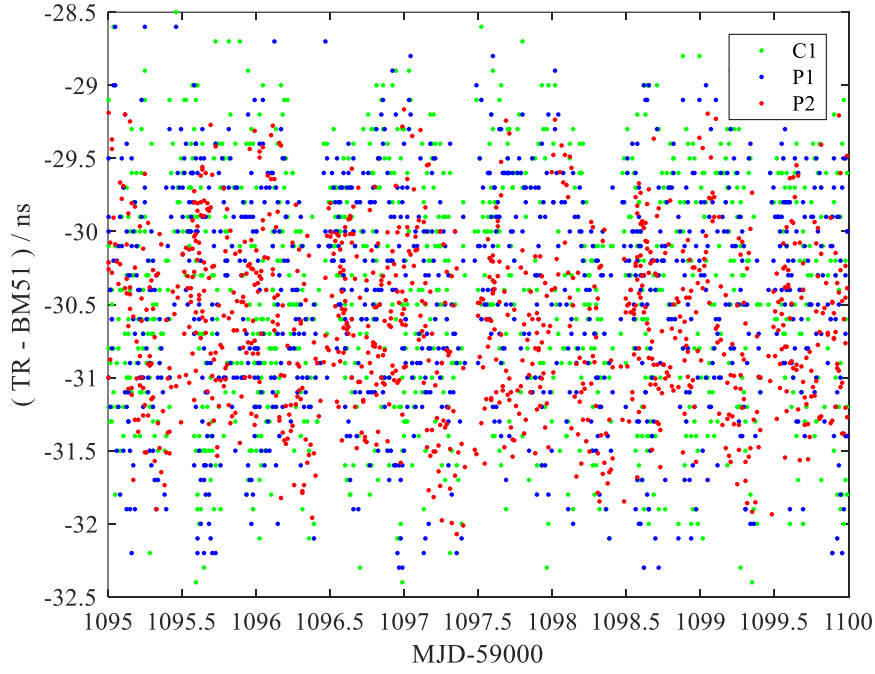
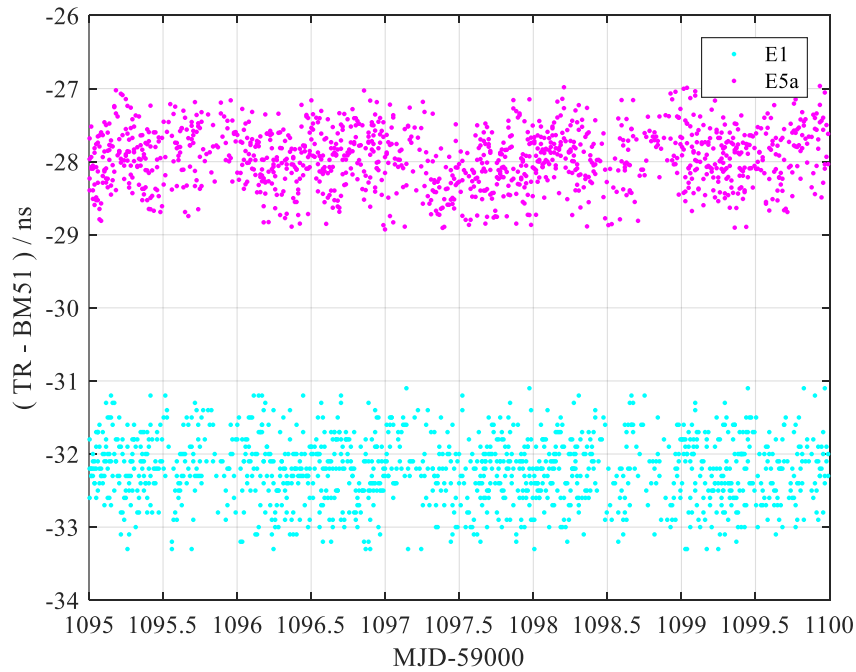

Figure 9-8: Galileo CCD at BIM



Acknowledgement

We are grateful to the Natural Resources Canada (NRCan) for the use of Precise Point Positioning (PPP) software for positioning computations.

Special thanks to our colleagues Elinor Trogrlić from IFS and Natasha Tosheva from BIM for the unreserved collaboration and support that they have provided.

END OF DOCUMENT