

Data submission guidelines (for UTC and rapid UTC)

Requirements for participation in UTC

See document [CCTF-WGMRA Guideline 8: Technical requirements for participation in UTC](#) . The laboratory information sheet (<https://webtai.bipm.org/database/documents/spreadsheet.docx>) has to be completed and reported to tai@bipm.org. Then the BIPM Time department will answer providing all necessary information to start data submission. For information about GNSS receivers available, see [infos-receivers.pdf](#).

Requirements for participation in rapid UTC (UTCr)

The contribution to rapid UTC is possible under the condition that the laboratory already contributes to UTC and is able to produce daily clock and time transfer files. To start contributing to UTCr, a laboratory has to send an email to tai@bipm.org (subject starting with "UTCr") to express its intention to participate in UTCr and an email contact address should be communicated in this message.

Data exchange procedure

A **laboratory** should only use FTP procedure to send data files. Laboratories post their data (clock data, time transfer data and Primary and Secondary Frequency Standards) on the BIPM FTP server following the standard names described below and the transmission must be done in ASCII format with carriage return character (CRLF) or line feed character (LF) as end of the line marker.

No file compression is allowed with the exception of RINEX data files.

All comments, notes or any other complement of information relative to the computation of TAI have to be sent in a separate message to "tai@bipm.org".

FTP access and authorizations (common for UTC and UTCr)

Connexions to BIPM FTP server can be done either by **FTP** (File Transfer Protocol) or for higher security by **FTPS** protocol (FTP over TLS (Transport Layer Security), using TLS explicit mode).

Each protocol can be used indifferently; the choice is left to the laboratories.

BIPM FTP server address is **tai.bipm.org** (IP: 5.144.141.242).

The port number for control connection is 21 and the server runs in passive mode for data connection with a port range between 50000 to 53000.

For FTPS protocol the TLS certificate is issued by a certificate authority (CA).

Individual FTP accounts are allocated to contributing laboratories.

A unique FTP account is used for data submission for both UTC and UTCr.

Each laboratory using its specific user account has writing privileges to its own directories and reading privileges to all directories.

On the FTP server, in the "soft" directory, programs for CGGTTS creation can be accessed.

A specific directory "temp" has been created for data exchange between different FTP-users, this folder is dedicated to additional data not to be used in Circular T.

On the BIPM Time Department database [webpage](#), useful documentation related to data submission and data format for Circular T is also available.

FTP structure and data files deposit

Data from each laboratory will be posted on specific directories, see FTP structure illustration below:

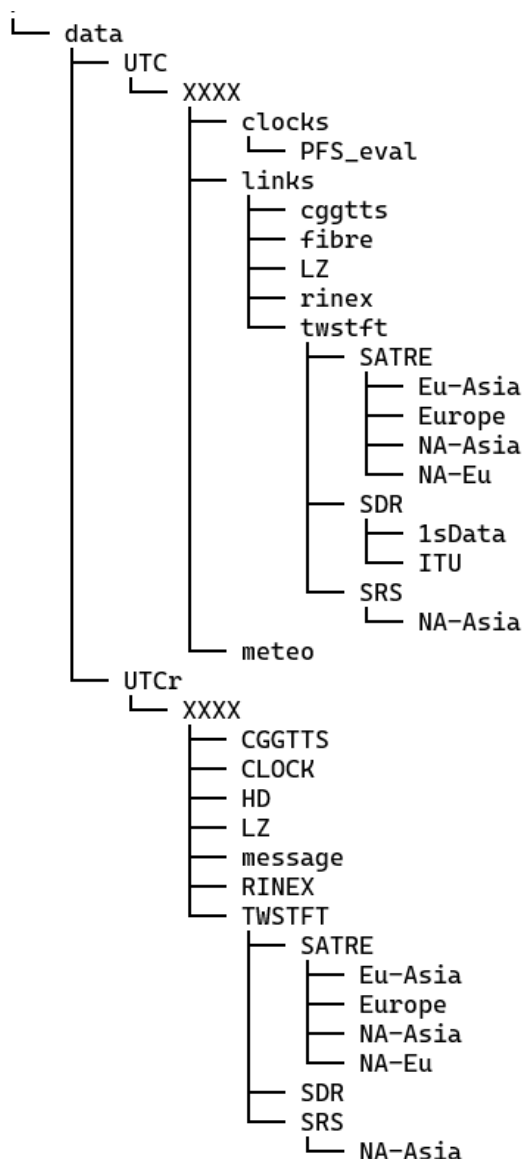

Regarding files submission for UTC:

Put your data in the remote directory `"/data/UTC/XXXX/"` where **"XXXX"** is the BIPM acronym of your laboratory, as in Section 1 of Circular T (see [laboratory list](#)).

Use the FTP data structure and put the data files in the appropriate subdirectory (refer to "Names convention" for more details on file names):

`/data/UTC/XXXX/clocks`

The standard name for the clock data files is: **CDLL_YY.MM** (see [format](#) and [clock codes](#))
New clocks have to be registered [here](#).

`/data/UTC/XXXX/clocks/PFS_eval`

The standard names for the PFS and SFS data files are the Circular T interval corresponding to the period of evaluation (see [PSFS format](#))

`/data/UTC/XXXX/links`

For time transfer data files exchange.

`/data/UTC/XXXX/links/cggfts`

-CGGTTS files named as for example : **GMLLmodd.ddd**, **GZLLmodd.ddd**, **RMLLmodd.ddd**, etc... (see [cggfts format v1](#) , [cggfts format v2](#), [cggfts format v2E](#), [CGGTTS headers](#)).

Check and update antenna coordinates in case of new values.

You may also create additional subdirectories in `"/links/cggfts"` if you have several receivers according to the name convention **LLmo**

`/data/UTC/XXXX/links/fibre`

- Optical fiber files named **FBAABBdd.ddd**

where **"AA"** and **"BB"** are the two alphabetical character codes of the two laboratories under comparison.

`/data/UTC/XXXX/links/LZ`

- LZ file: **LZLLmodd.ddd** needed for a GNSS station reference not referenced to UTC(k)(see [details](#))

`/data/UTC/XXXX/links/rinex` (see [details](#))

- Rinex files named **ssssdoy0.yyc.Z** (IGS receivers) or **LLmodoy0.yyc.Z** (not IGS receivers)

- Header files named **HDLLmodd.ddd** (not IGS station) or **HDssssdd.ddd** (IGS station)

`/data/UTC/XXXX/links/twstft/[modem]/[region]`

- files named **TWLABdd.ddd** (see [TW header](#))

[modem] = SATRE by default, SDR or SRS can be added on demand

`/data/UTC/XXXX/meteo` (starting from October 2017)

- Meteorological information (see [format](#)).

Please inform tai@bipm.org about any structure change of your specific directories.

Data submission deadline for UTC:

Data for Circular T participation must be uploaded before the 4th of the month following the month of the data, laboratories are encouraged to post data as soon as they are available. The use of daily data and their automated daily submission is recommended when applicable.

Regarding files submission for rapid UTC (UTCr):

The FTP directory structure is different from the one of UTC submission and there are some more additional specific directories. No modification in the structure is possible.

Note that the duration of data inside each file **must** not be longer than one day.

/data/UTCr/XXXX/CLOCK

daily clock data naming convention is **CDLL_dd.ddd**

/data/UTCr/XXXX/HD

for RINEX data, contains files **HDLLmodd.ddd** or **HDsssssdd.ddd** (case for IGS station) with information on receiver used and their regular updates when necessary (see format).

/data/UTCr/XXXX/LZ

link to UTC(k) data files, named **LZLLmodd.ddd** or **LZsssssdd.ddd** (case for IGS station) (see format).

/data/UTCr/XXXX/message

the information messages related to equipment (clock or time transfer) has to be communicated using informative text files **MELL_dd.ddd** which should be named according to the event's date and are free format and ASCII encoded.

Emails regarding UTCr should be sent to tai@bipm.org with subject of the email starting with "UTCr".

For other directories, there is no difference with the guidelines for data submission for Circular T.

Data submission deadline for UTCr:

Daily data upload are requested and data of day D must be uploaded before D+2, 12:00 UTC.

Publication of BIPM results

BIPM publications and files used in TAI computation are available at <https://www.bipm.org/en/time-ftp> .

Naming conventions

1) The 2-character identification of the file (first 2 characters of the filename)

"CD" stands for Clock Data

"LZ" stands for a link to UTC(k) file

"HD" stands for a header file (used with RINEX)

"TW" stands for a Two way satellite time and frequency transfer data file

"FB" stands for a FIBRE observation file

For CGGTTS data file, file name should be : **XFLLModd.ddd** .

For CGGTTS files up to version 02:

- o **X** is the code character indicating the constellation
 - "G" for a GPS ,
 - "R" for a GLONASS ,
 - "M" for mixed GPS+GLONASS,
- o **F** is the code character indicating the frequencies and channels:
 - "M" for a single-frequency multi-channel observation file
 - "Z" for a dual frequency observation file (always multi-channel)

For GNSS data files version 2E:

- o **X** is the code character indicating the constellation, using the same convention as in the RINEX standard :
 - "G" for a GPS ,
 - "R" for a GLONASS (R stands for Russia),
 - "E" for Galileo (Europe),
 - "C" for BeiDou (China),
 - "J" for QZSS (Japan),
 - "I" for IRNSS (India)
- o **F** is the code character indicating the frequencies and channels:
 - "M" for a single-frequency multi-channel observation file
 - "Z" for a dual frequency observation file (always multi-channel)

2) Special case for RINEX

RINEX files should be either RINEX 2.1, RINEX 3.x, or RINEX 4.x which file name should be : **ssssdoy0.yyc.Z** .

3) Acronyms used in patterns

"LLmo" is a unique GNSS station identifier (receiver + antenna), as follow :

"LL" is the two alphabetical character code for the laboratory

(see attached [list](#))

"m" is the receiver identification first character (your choice),
it can be "_" if not applicable or "0 to 9"

"o" is the receiver identification second character (your choice),
it can be "_" if not applicable or "0 to 9"

"ssss" is a 4-character acronym for the receiver (same as "LLmo" or IGS station ID, if applicable).

yy.mm are the year and the month of the data

"yy" are the last two digits of the year number

"doy" is the day of year number

dd.ddd is the MJD of the first observation in the file.

Versions history

Modification date	Change
12/04/2021	new BIPM website URLs
05/08/2021	New FTPS certificate
26/08/2025	Update directory structure, removed obsolete TWSTFT reference, Single frequency removed.